

SwissPlus Implant System, Part 2: Prosthodontic Aspects and Intersystem Comparisons

Joel L. Rosenlicht, DMD*

The need to simplify clinical procedures and improve the reliability and esthetics of restorations has resulted in an evolution of implant¹⁻⁶ and abutment designs over the last two decades.⁷⁻¹⁰ Restoring a two-stage implant with a cemented restoration has traditionally necessitated the purchase of a healing collar to maintain the soft tissue opening after the second-stage uncovering, an impression post and an implant replica to transfer the location of the implant platform to the working cast, and an abutment to support the restoration. To correct for undesirable implant angulation, gold abutments have often been used to serve as the base for custom-cast posts.

Today, many implant systems provide a wide variety of straight and angled abutments in different diameters, angles, and shapes to address a broad range of restorative applications. Individual abutment designs, however, may often differ from one system to another, because of the unique mechanical requirements of each implant design.¹¹⁻¹² Implant platforms,¹¹ for example, may vary according to the implant diameter and the type of implant-abutment connection (eg, internal hexagon, external hexagon, spline, friction post, conical, grooved, etc.). In addition, the esthetic approach to fixed partial denture restorations has spawned multiple abutment options with different diameters,

Incompatibility between implant systems and the increasing complexity of esthetic restorative options frequently require dentists to obtain special training in the selection and use of prosthetic components. SwissPlus System implants have been designed to simplify restorative procedures by eliminating many ancillary restorative components. The implants are packaged on a fixture mount that also functions as a transfer and as an abutment for cemented restorations. For multiple-unit, screw-retained restorations, the prosthesis can be splinted directly to

the top of the implant without an intermediate abutment. Overdenture attachments, straight, angled, screw-receiving, and custom-cast abutments complete the restorative system. This paper presents an overview of the SwissPlus System's prosthodontic aspects. Test data also illustrate intersystem compatibility and differences between SwissPlus System implants and ITI syn-Octa implants. (Implant Dent 2002; 11:249-257)

Key Words: dental implants, multifunctional components, full contour, interfacial gap

emergence profiles, cuff heights, angles, machined margins, and composition materials. Some systems also require a variety of corresponding healing collars and transfers to match the emergence profiles of the selected abutments. This proliferation of restorative components, compounded by the problem of intersystem design differences, may often necessitate special training merely to teach dentists how to properly select and use implant restorative components.

This paper reports on a new, one-stage implant system designed to simplify traditional clinical and laboratory procedures by eliminating many ancillary restorative components. The system comprises straight and tapered implant options. This report will present an overview of the prosthodontic system and its multifunctional components. In addition, results will be presented on *in vitro* evaluations conducted to determine the system's

prosthetic compatibility with another system.

MATERIALS AND METHODS

Prosthodontic Overview

Fixture mount/transfer. The SwissPlus System (Centerpulse Dental, Carlsbad, CA) features one-stage, straight and tapered implant designs with internal octagon (SwissPlus, Tapered SwissPlus) or internal hexagon (Tapered SwissPlus) connections (Figs. 1-2). Each implant is packaged on a fixture mount that interlocks with the implant's internal connection and overlaps the beveled edge of the implant's prosthetic platform. A 2-mm high surgical cover screw that matches the emergence profile of the fixture mount is included in the packaging. The fixture mount is designed to function with a ratchet or wrench-type drill to seat the implant into the osteotomy,

*Private Practice, Manchester, CT; Associate Clinical Professor, New York University.



Fig. 1. SwissPlus (left) and Tapered SwissPlus (middle) implants share a universal internal octagon prosthetic platform (right, top). A smaller diameter internal hexagon prosthetic platform (right, bottom) is also available for narrow interdental spaces.

then to serve as an implant-level impression post and transfer to fabricate a working cast (Fig. 2). This can be performed immediately upon seating the implant (stage 1),¹³⁻¹⁶ or after the nonsubmerged healing period and confirmation of osseointegration (stage 2).

Once the working cast has been fabricated, the combination fixture mount/transfer can be shortened on the working cast for use as a straight abutment, then sterilized and delivered to the patient. After tightening the abutment screw to 30 Ncm of torque in the implant, further modifications to the abutment may be completed intraorally by an intermittent cutting technique with diamond or carbide burs under copious irrigation.¹⁷ The full-contour profile of the abutment is designed to allow preparation of margins that follow the contour of the soft tissue. When all preparations are completed, the abutment is retightened to 30 Ncm, and conventional impression

procedures with retraction cord and elastomeric impression material are implemented. Alternatively, if a stage-1 impression technique is used, the fixture mount/transfer can be fully prepared on the working cast, then used as a removable die to fabricate a provisional prosthesis that is delivered immediately (stage 1), or after the nonsubmerged healing period (stage 2).

Stress distribution affects the long-term survival of dental implant restorations. When used as an abutment, the extensive geometrical locking of the combination fixture mount/abutment distributes forces deep within the implant and shields the abutment screw from excessive loading.¹⁸⁻¹⁹ Lateral forces are transmitted directly to the beveled outer shoulder of the implant from the mating bevel of the abutment, which provides greater resistance to the interface opening than butt-joint connections¹⁸ and further strengthens the entire assembly.

Implant-level castable copings.

For a multiple-unit, screw-retained tissue bar or denture, the castable coping may be used to fabricate a prosthesis that attaches directly to the top of the implant without an intermediate abutment. The components consist of either a plastic sheath, or a gold base and plastic sheath assembly, and a fixation screw. Instead of attaching the coping to an abutment, it rests passively on the implant's prosthetic platform, and the abutment fixation screw holds the coping in place. The copings are splinted on the working cast and waxed directly into the bar or framework pattern.

Tapered screw-receiving abutments. When additional vertical height is needed for multiple-unit, screw-retained restorations, the ACT Abutment is indicated. This tapered, screw-receiving abutment is threaded into the top of the implant and provides 1.6 mm or 3.0 mm of vertical height above the top of the implant platform. A variety of "cast-to" copings are available to facilitate fabrication of the prosthesis.

20° angled abutments. In the anterior maxillary jaw, implants must often be placed at a labial inclination to access an adequate volume of available bone for implant support. Full-contour, preparable, 20° angled abutments are designed to correct for undesirable implant angulation. After preparations, this nonrotational abutment can be restored with a cemented crown or bridge (Fig. 3). For optimum orientation of the angled head, indexing the implant's internal octagon at the time of implant placement is recommended. This is easily accomplished by positioning the flat surface of the implant's fixture mount either toward or opposite the desired direction of the abutment angle. That will position the angled head in the desired direction and thus minimize the need for preparation. The full-contour 20° angled abutment is designed to enable intraoral preparation of margins to follow the soft-tissue contour. This is performed using an intermittent cutting technique with diamond or carbide burs under copious irrigation.¹⁷ While custom-cast abutments are manufactured with the SwissPlus System, using the 20° angled abutments

may eliminate the additional time and expense required for casting.

Straight abutments. Straight abutments are used for fixed partial denture applications and are manufactured in full contour and narrow profiles. Full-contour straight abutments are prepared and used in a manner similar to fixture mount/transfers. Narrow straight abutments use the beveled shoulder of the implant's prosthetic platform as the restorative margin and include castable plastic copings that can also function as transfers. One-piece narrow straight abutments do not engage the implant's internal octagon and are, therefore, strictly used for splinted, multiple-unit restorations. After tightening the one-piece straight abutments into the implant using 30 Ncm of torque, the plastic copings are placed on the abutments, then picked up in an impression (Fig. 4). Shoulder abutment replicas are then inserted into the plastic copings and the impression is poured in dental stone. After separating the working cast, the copings are incorporated into the framework pattern for the restoration (Fig. 5).

Two-piece narrow abutments engage the implant's internal connection for antirotational stability and may, therefore, be used for single- or multiple-unit restorations. They are attached intraorally and restored in the same manner as the one-piece narrow abutments. Alternatively, because this component can be precisely repositioned on the implant, a transfer can be made of the location of the implant platform (implant-level transfer) using the implant's fixture mount and an implant replica. The two-piece narrow abutment can then be attached to the implant replica, shortened on the working cast, if necessary, and used as a die to fabricate the prosthesis with the plastic coping. Because restorations with narrow abutments seat directly onto the implant shoulders, they produce deep, subgingival margins. In contrast, the full-contour straight abutments allow preparation of the margins to follow the contour of the soft tissue, which can facilitate cement removal.

"Cast-To" gold abutments. When a screw-retained, combination post-and-crown restoration or a custom cast

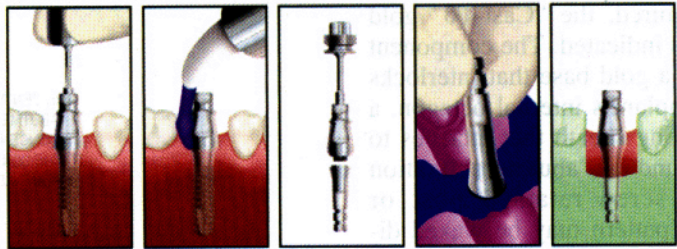

Fig. 2. Fixture Mount/Transfer/Abutment and Tapered SwissPlus: After healing, the multifunctional Fixture Mount is reattached and used as a transfer to fabricate a working cast. The component can then be prepared and used as an abutment for the restoration.

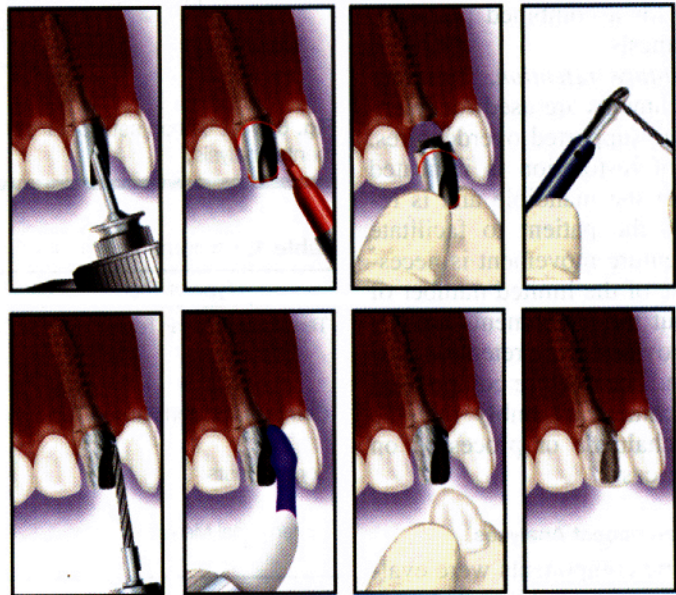

Fig. 3. 20° Angled Abutment: (Top, L to R): The abutment is attached to the implant, marked with the desired preparations, removed, and shortened for occlusal clearance. (Bottom, L to R): Margins are defined with a diamond bur intraorally, and impressions are made for fabrication of a cemented, porcelain-fused-to-metal (noble alloy) restoration.

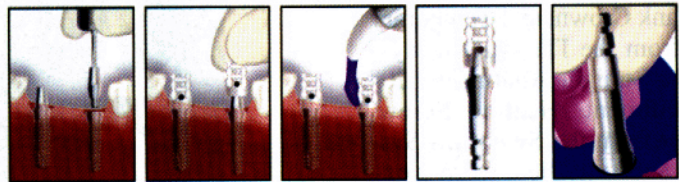

Fig. 4. Fixed Bridge: One-piece straight abutments and plastic copings are used to fabricate a working cast containing replicas of the implants in the patient's mouth.

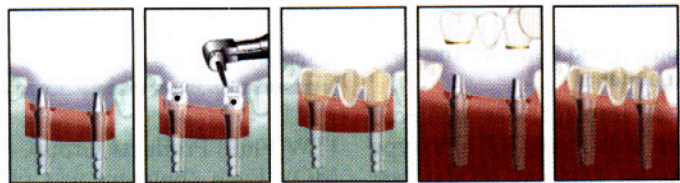

Fig. 5. Fixed Bridge: A porcelain-fused-to-metal bridge is fabricated with the plastic copings. The prosthesis is cemented onto the abutments.

post is required, the "Cast-To" gold abutment is indicated. The component consists of a gold base that interlocks with the implant's internal octagon, a plastic waxing sheath that attaches to the base, and an abutment fixation screw. A screw-retained post or framework pattern may be waxed directly over the sheath and base assembly, then cast in high noble alloy. A conventional porcelain-fused-to-metal crown can then be fabricated to cement over the cast post, or porcelain can be applied directly to the cast framework for a combined post-and-crown prosthesis.

Overdenture retention. Ball-and-socket attachments are used for retention of tissue-supported overdentures. This type of restoration is indicated primarily for the mandible and is removable by the patient to facilitate hygiene. Denture movement is necessary because of the limited number of implants, but the attachments are designed to provide secure retention during function. The denture components of the attachment assembly may be picked up chairside or processed on the working cast.

Prosthetic Component Analyses

Prosthetic components were evaluated for interchangeability between the SwissPlus and ITI synOcta (Institut Straumann AG, Waldenburg, Germany) implants through static compression bending, shear, tensile, and torsional testing (Table 1). Test components included the Solid Abutment, Octa TS Blank Crown, and Temporary Abutment from the ITI synOcta System, and the Straight Abutments, 20° Angled Abutment, Healing Screw, and Transfer from the SwissPlus System. Tolerance studies were conducted to determine if there was a tight mating interface between the assembled components without interference with any feature of the abutment or the abutment screw.

Interfacial Contact and Removal Torque of Straight Abutments

Each test implant was centered and fastened in the jaws of a V-type vise so that no rotation of the test implant was possible (Fig. 6). Test abutments were coated with manufacturing layout fluid (Dykem Steel Blue;

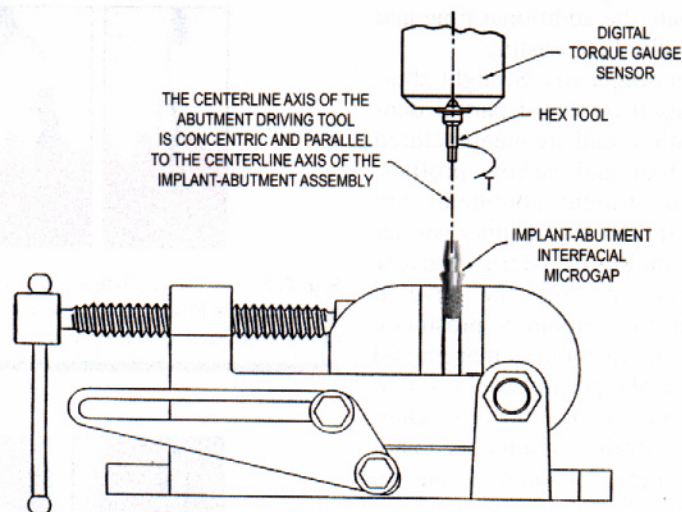

Fig. 6. Test station set-up for the Interfacial Contact and Removal Torque of Straight Abutments analysis.

Table 1. Equipment Used for Component Analyses

Type of Test	Equipment Name	Manufacturer
Tensile and Shear Tests	Chatillon Universal Electronic Tester, Model ET 1100	John Chatillon and Sons, Inc., Force Measurement Division, Greensboro, NC
Compression and Fatigue Tests	Instron Testing Machine, Model 8511	Instron Corporation, Canton, MA
Torque Tests	Mark-10 Digital Torque Gauge	Mark-10 Corporation, Hicksville, NY
Dimensional Measurements	RAM Optical Comparator	RAM Optical Instrumentation, Irvine, CA

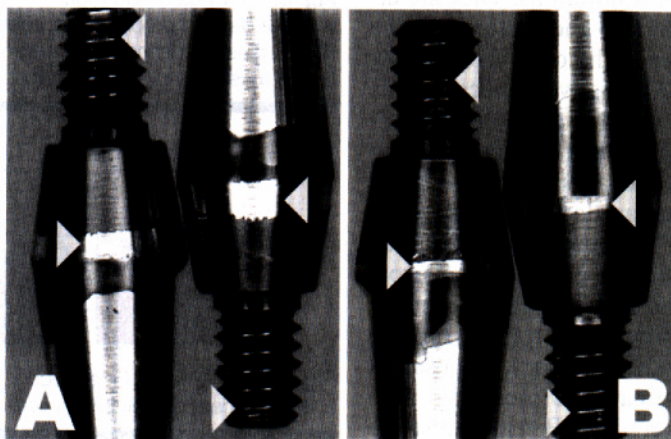

Fig. 7. SEM Analysis: SwissPlus abutments tightened to 30 Ncm, then removed from Tapered SwissPlus implants (A) and from ITI synOcta implants (B). Stain removal appeared on the major thread diameter of the abutment screws (arrows) and as a concentric ring at the implant-abutment interface (arrows).

ITW Fluid Products Group, St. Louis, MO). Each abutment was placed into the implant and the abutment screw was manually threaded into the implant with fingers until slight resis-

tance was encountered. The visual presence or absence of an interfacial gap between the internal walls of the implant and the external walls of the partially seated abutment was noted.

Table 2. Tolerance Test Results in Simulated High-Density Bone (Oak) with Interchanged Prosthetic Components

Type of Test	Type of Implant	Type of Abutment	Failure Mode	Average Maximum Force	
Compression	ITI synOcta 4.1 mm D, 10 mm L	SwissPlus combination Fixture Mount/Transfer/Abutment	Collar stretched, implant neck bent	231.6 kg	
Bending at 30 Degrees	SwissPlus 4.1 mm D, 10 mm L	ITI Solid Abutment, 6°, 5.5 mm L	Collar stretched, implant neck bent	198.1 kg	
		ITI synOcta Temporary Abutment	Collar stretched, implant neck bent	179.8 kg	
		ITI synOcta TS Titanium Blank Crown	Abutment broke at holes	129.0 kg	
Static Torsional Loading	ITI synOcta 4.1 mm D, 10 mm L	SwissPlus combination Fixture Mount/Transfer/Abutment	Abutment octagon	190.38 Ncm	
			Implant octagon		
		SwissPlus 4.1 mm D, 10 mm L	ITI Solid Abutment, 6°, 5.5 mm L	Not taken to failure	290.37 Ncm
			ITI synOcta Temporary Abutment	Not taken to failure	34.46 Ncm
Static Shear Loading	ITI synOcta 4.1 mm D, 10 mm L	SwissPlus Straight Abutment, 5.2 mm D	Not taken to failure	33.90 Ncm	
		SwissPlus 4.1 mm D, 10 mm L	ITI Solid Abutment, 6°, 5.5 mm L	Not taken to failure	15.42 kg
			ITI synOcta Temporary Abutment	Not taken to failure	3.87 kg
			ITI synOcta TS Titanium Blank Crown	Not taken to failure	3.86 kg
Tensile Loading	ITI synOcta 4.1 mm D, 10 mm L	SwissPlus Straight Abutment, 5.2 mm D	Not taken to failure	4.31 kg	
		SwissPlus 4.1 mm D, 10 mm L	ITI Solid Abutment, 6°, 5.5 mm L	Not taken to failure	54.46 kg
			ITI synOcta Temporary Abutment	Not taken to failure	54.50 kg
			ITI synOcta TS Titanium Blank Crown	Not taken to failure	55.21 kg
			Not taken to failure	54.75 kg	

To complete the seating procedure, the abutment's driving tool was inserted into a calibrated Digital Torque Gauge (Mark-10 Corporation, Hicksville, NY) that was connected to a digital monitor. After setting the torque gauge to operate in a clockwise direction, the assembled driving tool was inserted into the abutment screw while extreme care was taken to maintain the centerline axis alignment of all the components (Fig. 6). Torque was applied in 90° increments to the abutment screw until a maximum torque of 30 Ncm (recommended for the SwissPlus System) or 35 Ncm (recommended for the ITI synOcta System) was achieved. After a period of 10 minutes, the screw was retightened to the same torque level. The assembled components were examined microscopically and the presence or absence of a circumferential gap between the implant's internal walls and the external walls of the fully seated abutment was noted. After the assembled implant and abutment settled for 10 minutes, the torque wrench was operated in reverse mode to unthread the components. The maximum removal torque level was recorded from the digital monitor. Each abutment was then removed from the implant and subjected to close inspection to determine the points of contact with the internal walls of the implant.

RESULTS

Prosthetic Component Analyses

Prosthetic components from both systems were found to have the same dimensions at the implant-octagon interface. The interchanged implants and abutments provided no interferences to seating and achieved a tight mating interface when assembled. Tolerance test results are presented in Table 2.

Interfacial Contact and Removal Torque of Straight Abutments

Components tightened to 30 Ncm (Figs. 7, A and B; and 8, A and B).

Stain removal on the SwissPlus abutments retrieved from the Tapered SwissPlus implants (Fig. 7A) appeared as full, concentric rings at the implant-abutment interface and the major thread diameter of the abutment screw and on the top flanks of the screw threads. On SwissPlus abutments removed from ITI synOcta implants (Fig. 7B), stain removal was evident in the same locations but was slightly reduced in area. The ITI abutments removed from the ITI synOcta implants (Fig. 8A) demonstrated a patchy region of stain removal at the implant abutment interface. Interfacial

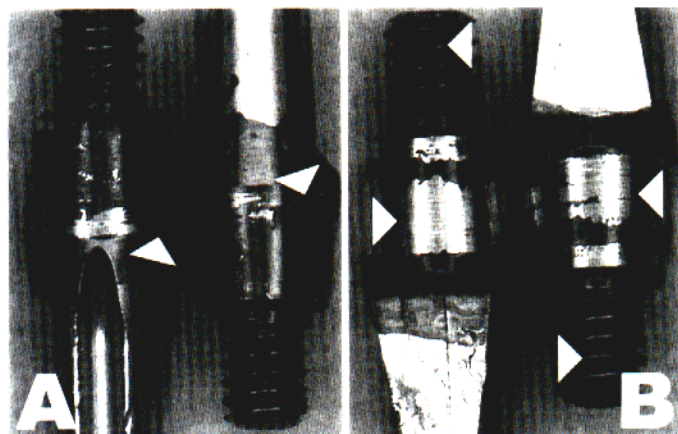

Fig. 8. SEM Analysis: ITI abutments tightened to 30 Ncm then removed from ITI synOcta (A) and Tapered SwissPlus (B) implants. Patchy areas of stain removal (see arrows) suggest the presence of interfacial gaps with the ITI synOcta implant. With the SwissPlus implants (B), with ITI abutment achieved contact from the implant-abutment interface to the major thread diameter of the abutment screws (see arrows).

Table 3. Straight Abutment Removal Torque

Sample	Tapered SwissPlus Implant			ITI synOcta Implant		
	SwissPlus Abutment Seating Torque (Ncm)		ITI synOcta Abutment Seating Torque (Ncm)	ITI synOcta Abutment Seating Torque (Ncm)		SwissPlus Abutment Seating Torque (Ncm)
	30 Ncm	35 Ncm	30 Ncm	30 Ncm	35 Ncm	30 Ncm
1	31.07	36.72	32.77	29.94	37.85	27.68
2	31.64	38.41	34.46	29.94	38.98	27.68
3	30.51	37.29	34.46	29.38	39.54	28.25
4	32.20	36.16	34.46	29.94	40.11	25.99
5	32.20	36.16	35.03	29.94	–	27.68
Average	31.52	36.95	34.23	29.83	39.09	27.34

stain removal was significantly increased on the ITI abutments that were assembled and removed from the Tapered SwissPlus implants (Fig. 8B). At 30 Ncm of abutment seating torque, the Tapered SwissPlus implant and abutment system demonstrated a higher average removal torque (31.52 Ncm) than the ITI synOcta implant and abutment (29.83 Ncm) (Table 3).

Components tightened to 35 Ncm (Fig. 9, A and B). Stain removal on SwissPlus abutments removed from ITI synOcta implants (Fig. 9A) demonstrated concentric rings of stain removal at the implant-abutment interface and on the major thread diameter of the abutment screws. Approximately three threads of the SwissPlus abutment screw achieved full engagement with the internal threads of the ITI synOcta implants. Stain removal was evident on the major diameter but not on the upper or lower flanks of the screw threads. A slightly greater degree of patchy stain removal was evident at the implant-abutment interface when the ITI System components were tightened to 35 Ncm (Fig. 9B) as opposed to 30 Ncm (Fig. 8A). However, even at the higher torque level, the areas of stain removal in the ITI system remained patchy. At 35 Ncm of abutment seating torque, the ITI

synOcta implant and abutment demonstrated a higher removal torque value (39.09 Ncm) than the Tapered SwissPlus implant and abutment (34.23 Ncm) (Table 3).

DISCUSSION

In the interfacial contact and removal torque analysis of straight abutments, the implant and abutment systems were tightened to the designated torque level, then separated. Removal of the stain material from the abutment suggested areas of tight, interfacial contact between the mated components. It was found that SwissPlus System components performed best when seated at 30 Ncm and that the ITI System components performed best when seated at 35 Ncm, just as they are designed to do.

When SwissPlus System abut-

ments were assembled and removed from Tapered SwissPlus implants, the concentric band of stain removal at the implant-abutment interface and on the major thread diameter of the abutment screw suggested that a tight interface was achieved between the components, regardless of attachment torque. This interface was also present in a diminished form on SwissPlus abutments that were assembled and removed from ITI synOcta implants.

When ITI System abutments were assembled and removed from the ITI synOcta implants, the patchy band of stain removal at the implant-abutment interface and on the major thread diameter of the abutment screw suggested the presence of interfacial gaps between the ITI synOcta components, regardless of at-

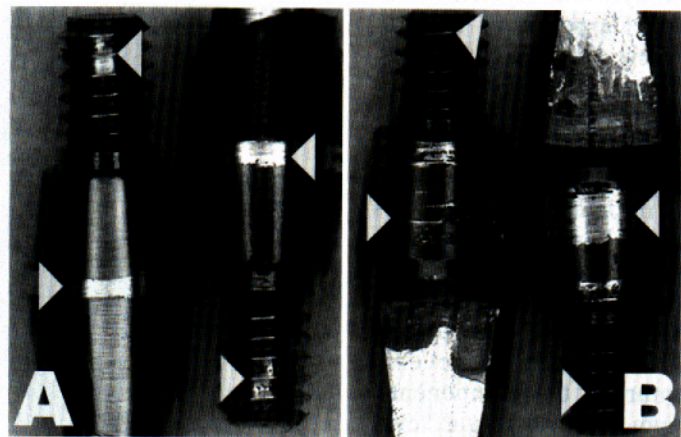

Fig. 9. SEM Analysis: SwissPlus abutments (left) and ITI abutments (right) removed from ITI synOcta implants after tightening to 35 Ncm. At the implant-abutment interface, the SwissPlus abutments achieved a clean band of stain removal, whereas the ITI abutments achieved a patchy band of stain removal. Both abutments exhibit stain removal on the major thread diameter of the abutment screws.

tachment torque. In one sample, there was no stain removal on one side of the implant-abutment interface and complete stain removal on the other side. The results in this report should be considered preliminary and more in-depth research is needed in this area.

CONCLUSIONS

The results of the present study demonstrated the interchangeability of restorative components between the SwissPlus and ITI synOcta implant systems. Interfacial contact tests with abutment stains indicated that an intimate, interfacial seal was achieved by SwissPlus abutments assembled on both SwissPlus and ITI synOcta implants, whereas ITI abutments assembled on ITI synOcta implants demonstrated the presence of interfacial gaps between the components.

ACKNOWLEDGMENTS

The author thanks Ines Aravena for contributing the manufacturing and test data, and Robert L. Riley, CDT and Michael M. Warner, MA, for assistance in researching, writing, and editing this paper.

DISCLOSURE

The author claims to have a financial interest in Centerpulse Dental whose product is mentioned in this article.

REFERENCES

1. Brånemark P-I, Hansson BO, Adell R, et al. Osseointegrated implants in the treatment of the edentulous jaw. Experience from a 10-year period. *Scand J Plast Reconstr Surg.* 1977;111:1-132.
2. Lubar RL, Katin RA. Implant systems incorporating the hollow-basket concept. *J Am Dent Assoc.* 1990;121:389-392.
3. English CE. Externally hexed implants, abutments and transfer devices: A comprehensive overview. *Implant Dent.* 1992;1:273-282.
4. Hahn J. Indications for the use of tapered dental implants. *Dent Surg Prod.* 1997;2:34-38.
5. English CE. Cylindrical implants. *J Calif Dent Assoc.* 1988;16:17-26.
6. Chess JT. Technique for placement of root form implant of the finned or serrated type. *J Am Dent Assoc.* 1990;121:414-417.
7. Lewis SF, Llamas D, Avera S. The UCLA abutment: A four-year review. *J Prosthet Dent.* 1992;67:509-515.
8. Yildirim M, Edelhoff D, Hanisch O, et al. Ceramic abutments—A new era in achieving optimal esthetics in implant dentistry. *Int J Periodont Rest Dent.* 2000;20:81-91.
9. Gelb DA, Lazzara RJ. Hierarchy of objectives in implant placement to maximize esthetics: Use of pre-angulated abutments. *Int J Periodontics Restorative Dent.* 1993;13:277-287.
10. Preiskel HW, Tsolka P. The DIA anatomic abutment system and telescopic prosthesis: A clinical report. *Int J Oral Maxillofac Implants.* 1997;12:628-633.
11. Binon PP. Implants and components: Entering the new millennium. *Int J Oral Maxillofac Implants.* 2000;15:76-94.
12. Watson PH. Development and

manufacture of prosthodontic components: Do we need a change? *Int J Prosthodont.* 1998;11:513-516.

13. Weiss CM, Weiss A, Rosenlicht J. Root form implants. Treatment of total mandibular edentulism diagnosed for an overdenture. In: Weiss CM, Weiss A, eds. *Principles and Practice of Implant Dentistry.* St. Louis: Mosby; 2001:147-168.

14. Rosenlicht J. Advanced surgical techniques in implant dentistry. Contemporary applications of early techniques. *Implant Soc.* 1994;4:1,6,11.

15. Rosenlicht J. Implant dentistry techniques. Beginning the restorative process at the time of surgery with the Immediate Impression implant system from Steri-Oss. *Dent Products Report.* 1996;28:32-33.

16. Rosenlicht JL. Simplified implant dentistry for the restorative dentist: Integrating the team approach. *Int J Dent Symposia.* 1996;III:56-59.

17. Gross M, Laufer B-Z, Ormianar Z. An investigation on heat transfer to the implant-bone interface due to abutment preparation with high-speed cutting instruments. *Int J Oral Maxillofac Implants.* 1995;10:207-212.

18. Binon PP. The evolution and evaluation of two interference-fit implant interfaces. *Postgrad Dent.* 1996;3:3-13.

19. Merz BR, Hunenbart S. Mechanics of the implant-abutment connection: An 8-degree taper compared to a butt joint connection. *Int J Oral Maxillofac Implants.* 2000;15:519-526.

Reprint requests and correspondence to:
Joel L. Rosenlicht, DMD
483 Middle Turnpike West
Manchester, CT 06040-3864



AUTOR: Joel L. Rosenlicht, DMD*, *privat praktizierender Arzt, Manchester, CT; A.O. Professor für Medizin, Universität von New York. Schriftverkehr: Joel L. Rosenlicht, DMD, 483 Middle Turnpike West, Manchester, CT 06040 - 3864

ZUSSAMENFASSUNG: Da sich verschiedene Implantierungssysteme in der gemeinsamen Anwendung als miteinander unverträglich erwiesen und die ästhetischen Wiederherstellungsmöglichkeiten weiter zugenommen haben, müssen die behandelnden Zahnärzte eine spezielle Fortbildung bezüglich Auswahl und angemessene Anwendung der prothetischen Mittel durchlaufen. Die Implantate der SwissPlus Serie sind aufgrund ihres Ausschlusses untergeordneter Wiederherstellungskomponenten speziell für die Vereinfachung des Wiederherstellungsprozesses geeignet. Die Implantate werden auf einen Anlagerungsträger aufgebracht, der gleichzeitig als Transfermedium fungiert und eine Stützfunktion für zementierte Prothesen übernimmt. Bei mehrzahnigen schraubenfixierten Wiederherstellungsobjekten kann die Prothese direkt ohne Einsatz eines zwischengeschalteten Stützapparates auf die Oberfläche des Implantates eingeschient werden. Deckprothesenbefestigungen, gerade, gewinkelte, schraubenge tragene und speziell angefertigte Stützkomponenten vervollständigen das Komplettsystem. Der vorliegende Bericht bietet einen Überblick der prothetischen Aspekte des SwissPlus Systems. Darin enthalten sind auch Testdaten, die die Verträglichkeit der Serie mit anderen Systemen dokumentieren sowie die Unterschiede zwischen SwissPlus Implantaten und ITI Syn-Octa Implantaten festhalten.

SCHLÜSSELWÖRTER: Zahnimplantate, multifunktionelle Komponenten, volle Randbildung, Zwischenflächenspalt

AUTOR: Joel L. Rosenlicht, DMD* *Práctica privada, Manchester, CT; Profesor Clínico Asociado, New York University. Correspondencia a: Joel L. Rosenlicht, DMD, 483 Middle Turnpike West, Manchester, CT 06040-3864

ABSTRACTO: La incompatibilidad entre los sistemas de implantes y la mayor complejidad de las opciones de restauración estética frecuentemente requieren que los dentistas obtengan capacitación especial en la selección y utilización de componentes protéticos. Los implantes del Sistema SwissPlus han sido diseñados para simplificar los procedimientos de restauración al eliminar muchos componentes auxiliares de restauración. Los implantes vienen empaquetados en un montante que también funciona como transferencia y como pilar para las restauraciones con cemento. Para las restauraciones retenidas con tornillos de múltiples unidades, la prótesis puede entablillarse directamente a la parte de arriba del implante sin un pilar intermedio. Accesorios de sobredentaduras, y pilares rectos, angulares, de recepción del tornillo y con moldes especiales completan el sistema de restauración. Este trabajo presenta una reseña de los aspectos prostodónticos del Sistema SwissPlus. Los datos de las pruebas también ilustran la compatibilidad entre sistemas y las diferencias entre los implantes del Sistema SwissPlus y los implantes syn-Octa de ITI.

PALABRAS CLAVES: implantes dentales, componentes multifuncionales, contorno completo, espacio interfacial

AUTOR: Joel L. Rosenlicht, DMD*. *Clínica particular, Manchester, CT, Professor Clínico Asociado, Universidade de Nova York. Correspondências devem ser enviadas a: Joel L. Rosenlicht, DMD, 483 Middle Turnpike West, Manchester, CT 06040-3864

SINOPSE: a incompatibilidade entre os sistemas de implantes e a crescente complexidade das opções restauradoras estéticas frequentemente exigem que dentistas obtenham um treinamento especial quanto à seleção e à utilização dos componentes protéticos. Os implantes do sistema SwissPlus foram projetados para simplificar os procedimentos restauradores ao eliminarem vários componentes restauradores auxiliares. Os implantes são condensados em uma moldura de fixação que também funciona como transferência e *abutment* para as restaurações cimentadas. Para as restaurações retidas por parafuso de unidade múltipla, o esplinte da prótese poderá ser posicionado diretamente sobre o implante sem um *abutment* intermediário. As presilhas de *overdentures* e os *abutments* retos, angulados, receptores de parafusos e os *abutments* de moldagem sob medida completam o sistema restaurador. Este trabalho apresenta uma visão geral dos aspectos protéticos do sistema SwissPlus. O texto também exhibe a compatibilidade intersistêmica e as diferenças entre os implantes do sistema SwissPlus e os implantes ITI do sistema syn-Octa.

PALAVRAS-CHAVES: implantes odontológicos, componentes multifuncionais, contorno completo, fenda interfacial.

SwissPlus™インプラント・システム、パート2: 補綴歯科学上の要因と他システム比較

著者: ジョエル・L・ローゼンリクト、DMD*

概要: 審美的修復法における次第に複雑化する選択肢とインプラント・システムとの間の相互適合性の欠如のために、今日の歯科医には補綴componentの選択と使用について特別の訓練を受ける必要が生じている。SwissPlusシステムは、補助的修復用componentの多くを除去して修復過程を単純化するためにデザインされた。Multiple-unitのネジで保持された修復では、補綴は介在的アバットメントなしでインプラント上に直接付設することができる。オーバーデンチャー・アタッチメント、まつぐの/曲がった/ネジ受け入れ型またはカスタムキャストのアバットメントで修復システムが完成される。本論文はSwissPlusシステムの概観を、補綴に関連する局面を中心に紹介する。SwissPlusシステム・インプラントとITI syn-Octaインプラントの相互適合性と違いを示すテストデータも提供される。

キーワード: デンタル・インプラント、多機能component、全輪郭、インターフェーシャル・ギャップ

*コネチカット州マンチェスターにて開業；ニューヨーク大学准教授

問い合わせ先: Joel L. Rosenlicht, DMD, 483 Middle Turnpike West,
Manchester, CT 06040-3864